

DPX-20510

FPT Generator

Prime: 280KW/350KVA

Standby: 308KW/385KVA

Technical Data

Model		385kva
Prime power	kva	350
	kw	280
Standby power	kva	385
	kw	308
Rated voltage line to line	V	400
Rated current	A	505,2
Maximun sound level for silent	dB@7m	75

Engine-FPT

Model		CURS0R13TE2A.S551
Aspiration		Four-stroke, water-cooled, 6 cylinders,in line, turbo charged and after cooled
No. cylinders		6
Displacement	L	12,88
Bore*Stroke	mm	135x150
Compression ratio		16.5:1
Rated speed	r/min	1500
Governor		ECR
Emission level		Euro II
Size	mm	2324x1270x1546.5
Fire order		1-4-2-6-3-5
Start Motor	V	24

Exhause System

Max exhaust back pressure	kPa	5
---------------------------	-----	---

Air intake System

Max inlet pressure (Dirty air)	kPa	5
Max inlet pressure (Clean air)	kPa	2

Fuel System

110% load(Standby power)	L/h	83,6
100% load(Prime power)	L/h	71
75% load(Prime power)	L/h	54
50% load(Prime power)	L/h	35,5
25% load(Prime power)	L/h	20,5
Fuel capacity for silent genset	L	550
Fuel capacity for open genset	L	550

Lubrication System

Max oil temperature	°C	120
Oil capacity including filters	L	35
Oil capacity Max	L	27
Oil capacity Low	L	14

Cooling System

Coolant capacity in engine	L	19,5
Coolant capacity with radiator	L	38,1
Pressure cap setting	kPa	70
Coolant engine flow	L/min	460,525
Shutdown switch setting	°C	103

Standard Features

Engine(FPT Engine)	●
Radiator 50°C max,fans are driven by belt	●
12/24V charge alternator	●
Alternator: single bearing alternator IP23	●
insulation class H/H	●
Standard auto control system	●
One set of air filter, fuel filter, oil filter	●
Main line circuit breaker / ACB	●
Base fuel tank	●
One 12V/Two 24V batteries, rac and cable	●
Exhaust system(Ripple flex exhaust pipe)	●
Exhaust siphon, flange, muffler	●
User manual	●
Battery charge	●
Water heater	●

Options

Alternator heater	<input type="radio"/>
PMG	<input type="radio"/>
Water oil separator	<input type="radio"/>
Daily fuel tank	<input type="radio"/>
Remote control panel	<input type="radio"/>
Automatic transfer switch/ATS	<input type="radio"/>
Switch box	<input type="radio"/>
Standard: ●	Options: ○

Alternator

Model		TAL-A46-H
Alternator Brand		LERROY SOMER
Phase		3
Voltage	V	400
Wiring Type		6 wires
Bearing		1
Power factor		0,8
Frequency	Hz	50
Prime power	KVA	365
Exciter Type		Brushless, self-excitation
Voltage regulation	%	±0.5
Protection Grade		IP 23
Insulation grade		H

Controller-Deepsea

Model DSE 7320

- 7 configurable digital inputs
- Built-in governor and AVR control
- Base load (kW export) functionality
- Mains (utility) de-coupling protection
- Generator power (kW, kVA) monitoring
- Overload (kW & kV Ar) protection
- Emergency stop
- Start failure



Unit Dimensions(Basic unit)

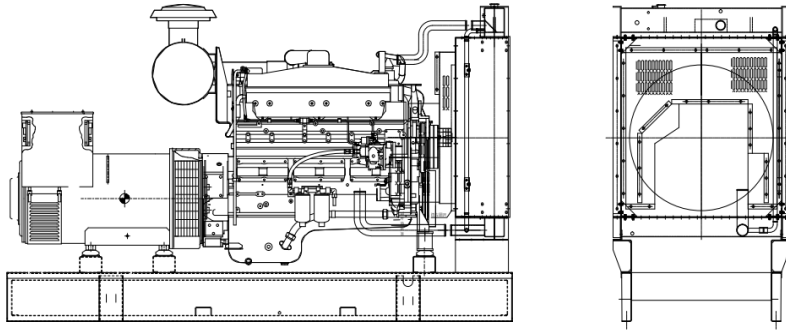

Open Type

L*W*H

mm

3300x1650x2000

Weight

kg

3400

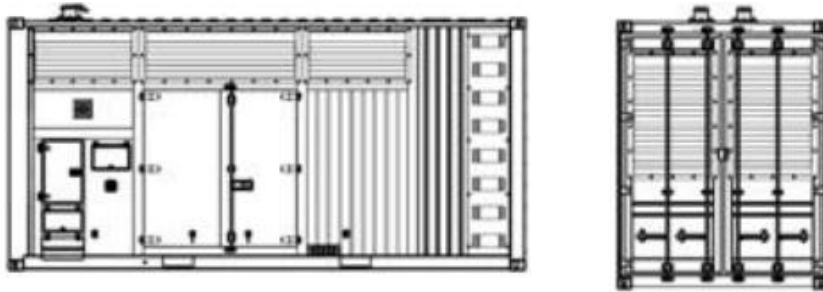

Silent Type

L*W*H

mm

+/- 4160x1480x2150

Weight

kg

+/- 4175

Warranty

FPT Engine

12 months from date of purchase or 1000 hours.

Generator

12 months from date of purchase or 1000 hours

(whichever comes first).