

CHRONOFLASH® 40

NF E 52081 - E 52082

DIN 15018 H1 B3 K3



CADILLON

Cotes

Abmessungen

Dimensions

Dimensiones

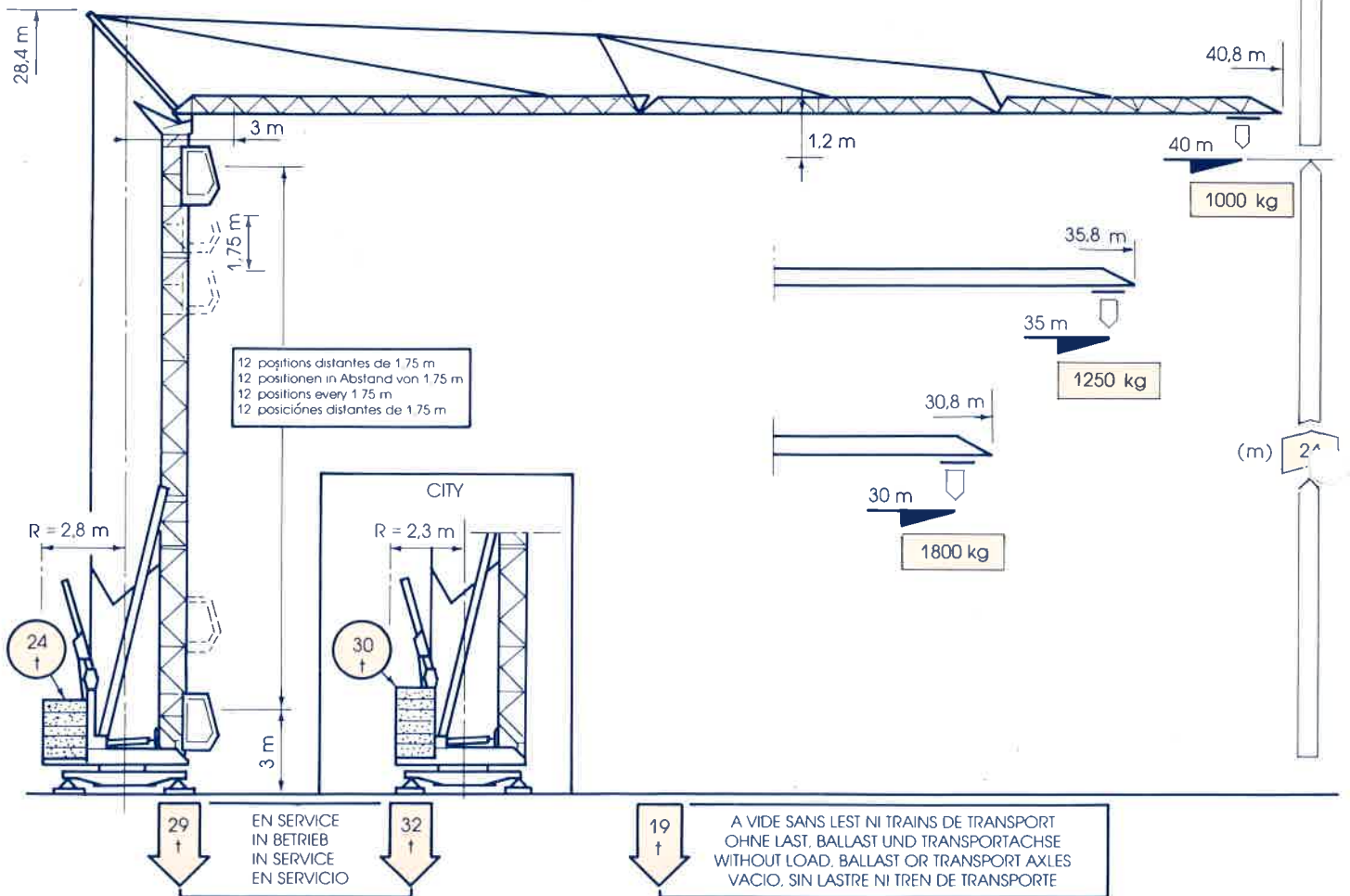
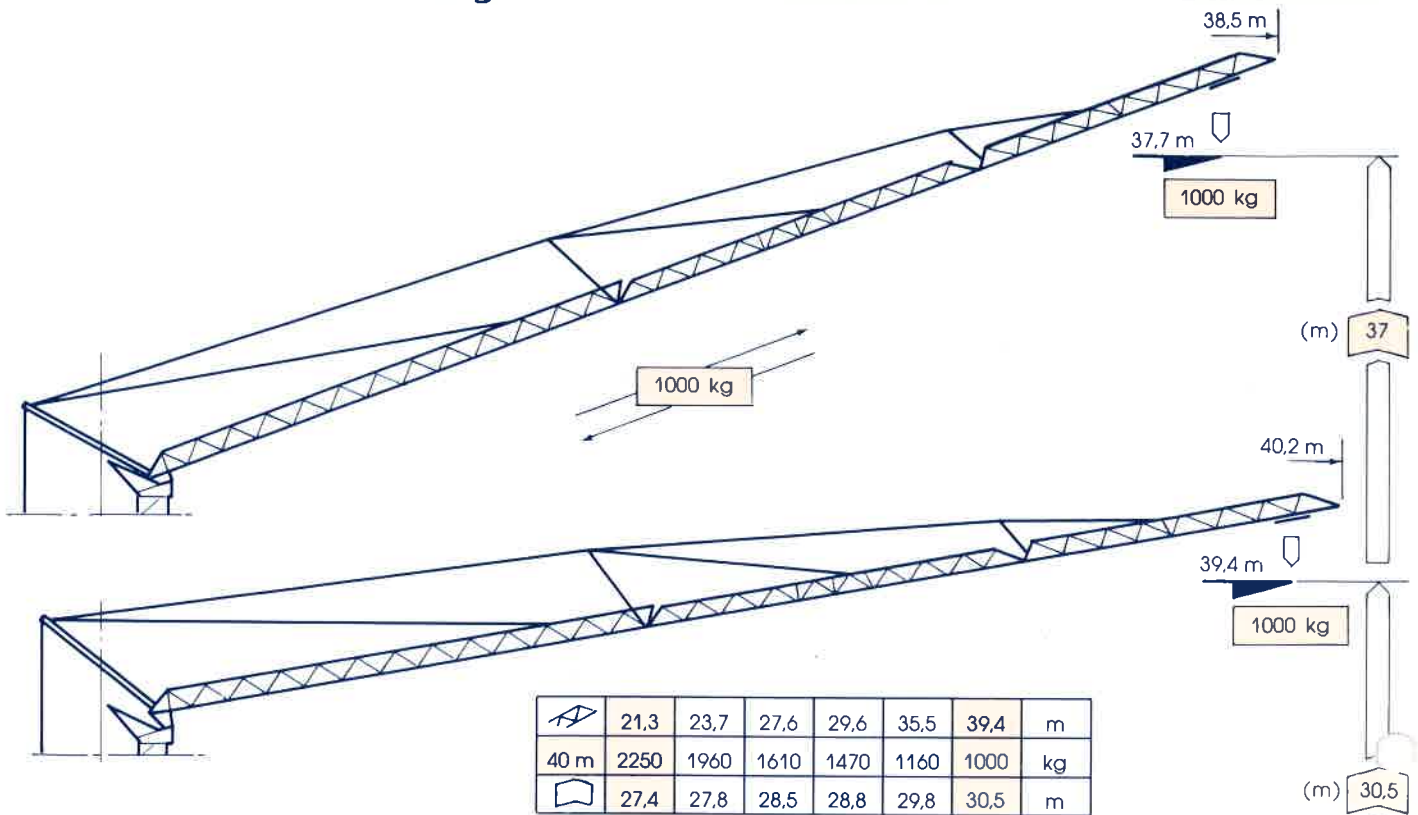

CHRONOFASH 40

S/D		12,5	12,9	14,4	15	16	18	20	22	24	26	28	30	33	35	38	40
	40 m	4500	4350	3750	3570	3290	2830	2480	2190	1960	1770	1610	1470	1300	1200	1070	1000
	35 m		4500	3890	3700	3410	2930	2570	2280	2040	1840	1670	1530	1350	1250		
	30 m			4500	4280	3950	3410	2990	2660	2380	2160	1960	1800				kg

Courbes de charges

Lastkurven

Load curves

Curvas de cargas

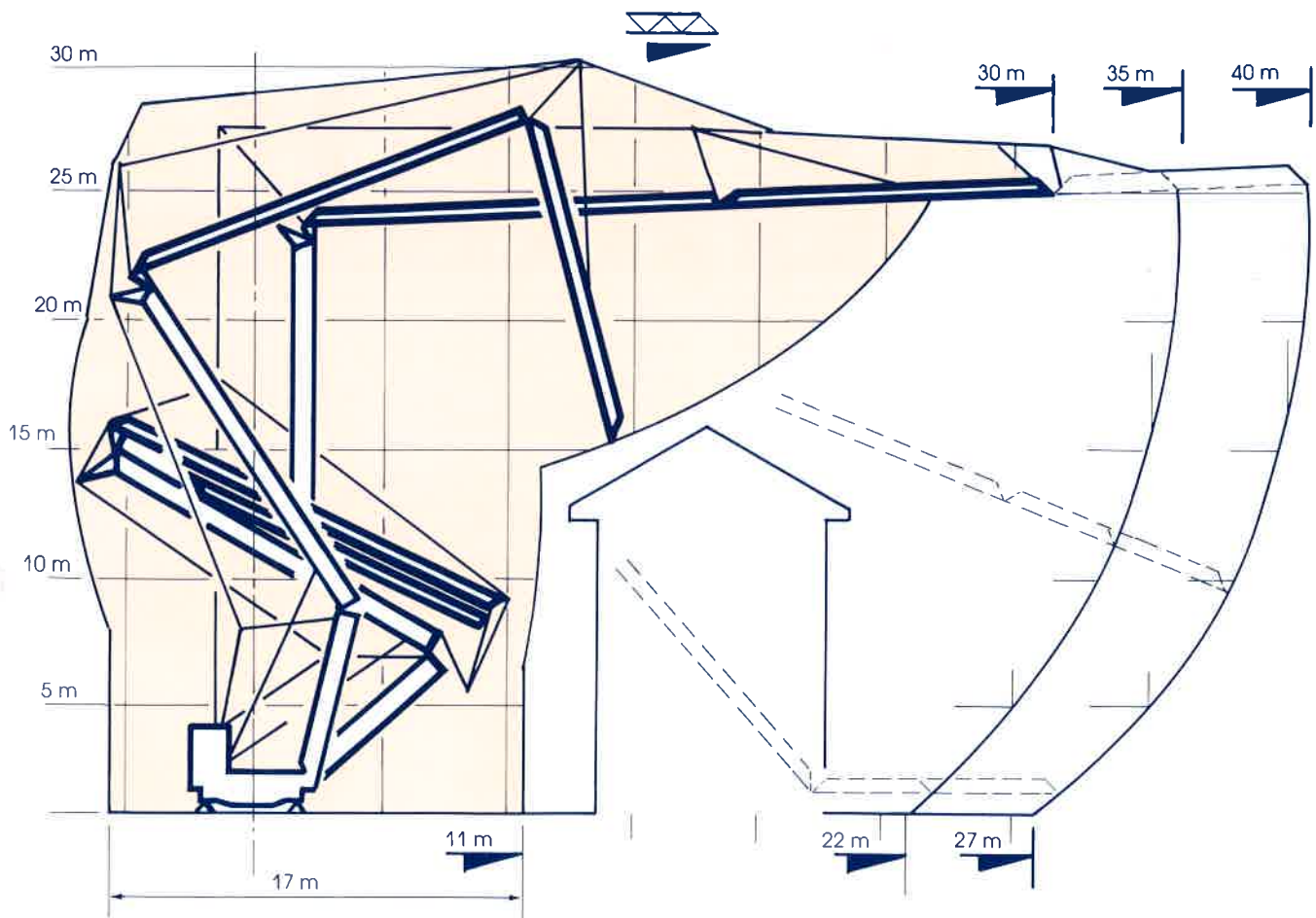

ENCOMBREMENT AU MONTAGE
SPACE REQUIREMENT

ABMESSUNGEN
ENCOMBRAMIENTO

CHRONOFALSH 40		m/mn	KW	ch PS - HP	kg
	I	3	4	5,5	4500
	II	12,5	11	15	4500
	III	25	15	20	3000
	I	6	4	5,5	2250
	II	25	11	15	2250
	III	50	15	20	1500
		0,15 > 0,4 > 0,8	5	6,8	
	I	22,5	4	5,5	
	II	45			
		0 > > 25	2 x 2,2	2 x 3	
			5,5	7,5	

V	380	450
Hz	50	60
kVA	25	30

- GROUPE ELECTROGENE
NOUS CONSULTER
- STROMAGGREGAT
AUF ANFRAGE
- GENERATOR SET
CONSULT US
- GRUPO ELECTROGENO
CONSULTARNOS

*

Multiplier par 1,2 pour 450 V
Multiplizieren bei 1,2 für 450 V
Multiply by 1,2 for 450 V
Multiplicar por 1,2 para 450 V

Versions sur chassis

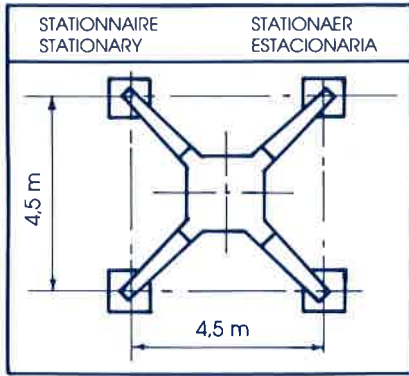

Unterwagen

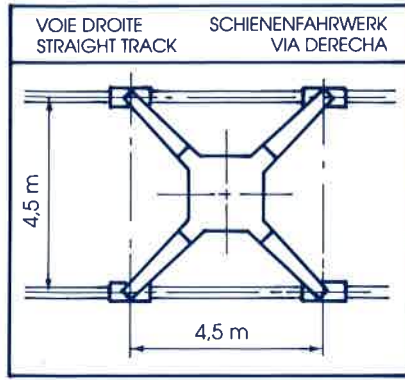

Undercarriage

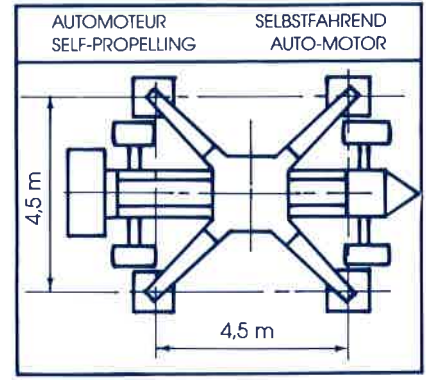

Chasis

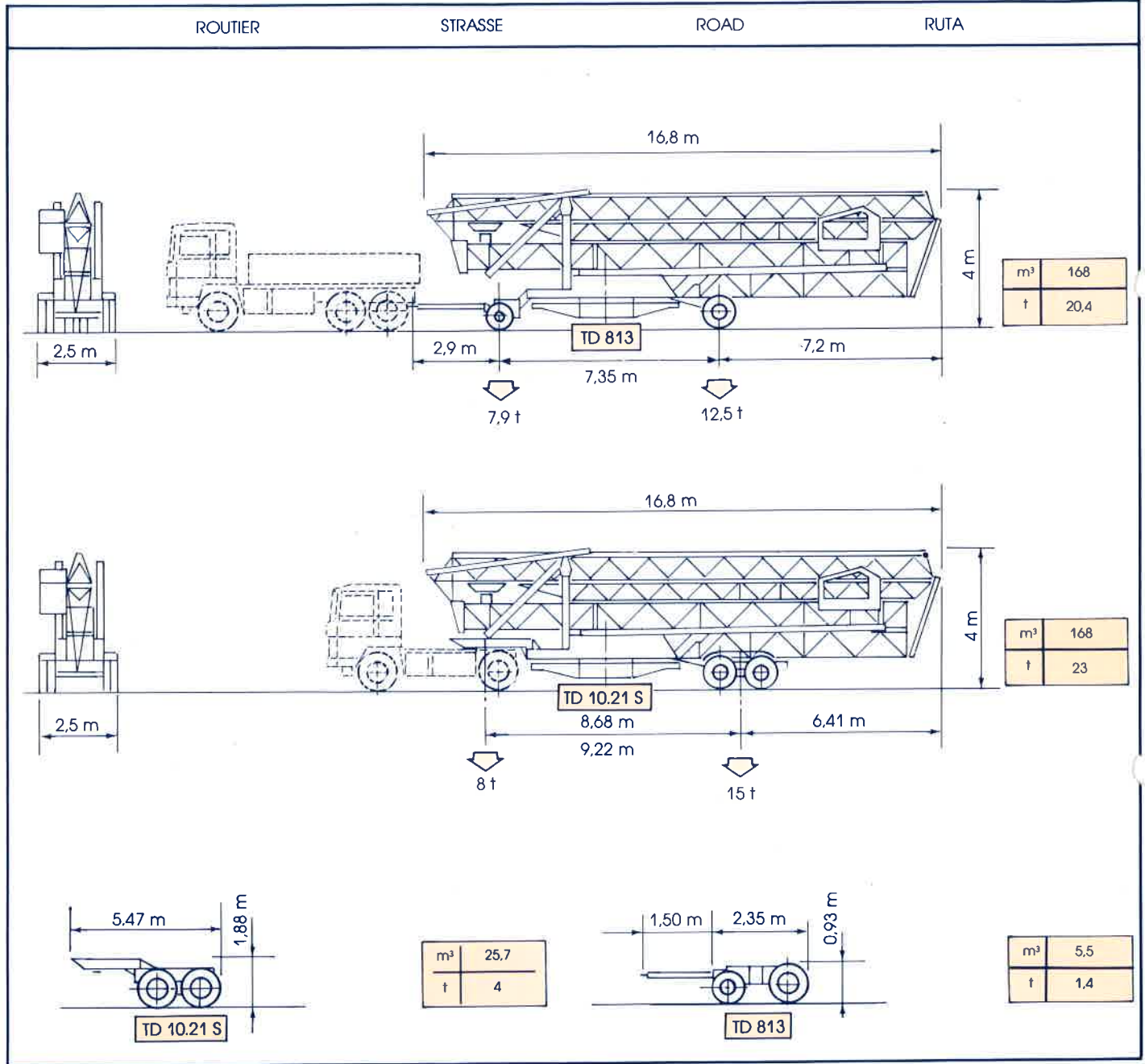

Transport

Transport

Transport

Transporte



CADILLON

CADILLON INDUSTRIE : 8, rue de Pretin - B.P. 25 - F 71120 CHAROLLES - FRANCE
Tél. 85 24 09 34 - Télex 800 418 - Télécopie 85 88 34 10

Filiale - Subsidiary - Filiale - Sucursal :

CADILLON BAUMASCHINEN G.m.b.h. : Am Dornbusch 4 - D 6108 WEITERSTADT
R.F.A. - Tél. 19 49 6151 85041 ou 85042 ou 85043
Télécopie 19 49 6151 82535 - Télex 041419223 +

CADILLON BAUMASCHINEN A.G. : Hofstr. 15 - CH - 8181 HORI
Tél. (19.41) 1.861.15.65 - Télécopie (19.41) 861.1250

CADILLON U.S.A. Inc. : 5777 West Century Boulevard - Suite 520 - LOS ANGELES
CALIFORNIE 90045 - Té. 19.1.213.216.0060 - Télécopie 19.1.213.410.1017